

Vertera™

Teller cash recycler

Enhanced banknote authentication and fitness sorting

The optimization of cash management calls for specialist experience, resources and truly innovative technology. Across the world, Talaris' cash management solutions are trusted by thousands of organizations to ensure their cash is managed securely and efficiently while delivering the ultimate in productivity.

The Vertera cash recycler from Talaris represents a significant evolution in teller automation technology, enabling financial institutions to provide exceptional service while increasing customer engagement.



The Vertera delivers real benefit for businesses at multiple levels and provides a comprehensive and integrated solution to address the demands of the customer, the teller and improvements in branch efficiency.

- **Provides a fast, efficient service for clients** with fewer lines and a more personalized service that only a fully supported and attentive teller can provide
- **Reduces monotonous and repetitive tasks** as the Vertera provides a highly efficient and secure cash recycling solution

- **Advanced authentication and fitness sorting** capabilities, ensuring a robust first-line-of-defense for the branch
- **Optimizes branch business processes** with deployment flexibility designed into the solution, virtually eliminating start-of-day and end-of-day set up activities
- **Compact design** that provides the flexibility to fit seamlessly into the working environment
- **Fifth generation recycling technology** providing trusted reliability and performance

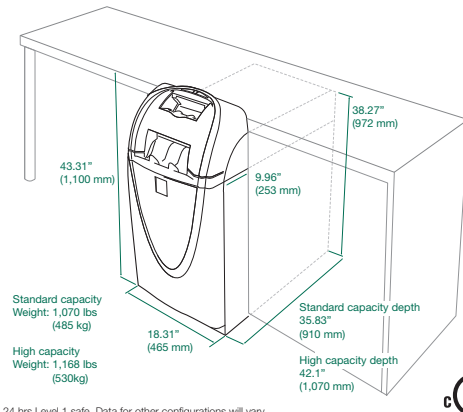
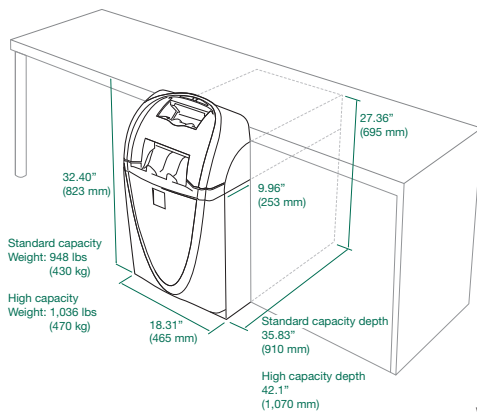

Weights and dimensions shown are for UL 291 24 hrs Level 1 safe. Data for other configurations will vary. Please contact your account manager for details.



Product specifications

Roll storage system	8 roll storage modules	Note deposit	5 notes per second, up to 300 notes per bundle
Capacity	Standard capacity - up to 350 notes/module High capacity - up to 600 notes/module	Note dispense	5 notes per second, up to 100 notes per bundle
Interfaces	2 RS232 C serial ports 2 RS232 C, LAN/Ethernet with optional PC	Options	Journal printer Uninterruptible power supply Additional RS232 C interfaces Connectivity to all open network architectures Two drop deposits LAN network interface unit Connectivity software InstaChange® coin dispenser
Authenticity detectors	Visible, Infrared, UV, Magnetic Ink Authenticity detectors configured to the specific currencies required		
Power Supply	100 - 240 V AC 50/60 Hz		

North American Headquarters
2441 Warrenville Road
Lisle, IL 60532
United States
T +1 800.527.2638
www.talaris.com

